

DATA SHEET

NEXEM

RoHS2 Compliant

MINIATURE SIGNAL RELAY

EC2/EE2 SERIES

COMPACT SIZE, SLIM-PACKAGE

DESCRIPTION

NEXEM EC2/EE2 relay is a standard miniature signal relay, compact and slim.

FEATURES

- Compact and light weight
- FCC (1500 V) and Telcordia (2500 V) surge capacity
- UL recognized and CSA certified
- Low power consumption (100-230 mW)
- NQJ, NQX type (High power switching) is UL recognized for 30Vdc, 3A (resistive load), supports maximum switching power of 60W and maximum carrying current of 3.2A
- ND type (High insulation) conform to supplementary insulation for EN62368-1
- NKX type (High breakdown voltage) can withstand 1.5KVac between normally open contacts
- Moisture Barrier Bag (MBB) packaged EE2 relays meet moisture sensibility level (MSL) of IPC/JEDEC-STD-020.

APPLICATIONS

Test Equipment, Electronic switching systems, PBX, Terminal equipment, Telephone system

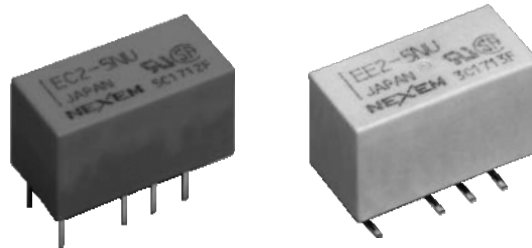

For Right Use of Miniature Relays

DO NOT EXCEED MAXIMUM RATINGS.

Do not use relays under exceeding conditions such as over ambient temperature, over voltage and over current. Incorrect use could result in abnormal heating, damage to related parts or cause burning.

READ CAUTIONS IN THE SELECTION GUIDE.

Read the cautions described in EM Devices' "Miniature Relays" when you choose relays for your application.

The information in this document is subject to change without notice.

© EM Devices Corporation 2026



- All specifications in this catalog and production status of products are subject to change without notice. Prior to the purchase, please contact EM Devices for updated product data.
- Please request for a specification sheet for detailed product data prior to the purchase.
- Before using the product in this catalog, please also read "NOTES ON CORRECT USE" in the selection guide

MARKINGS (Top view)

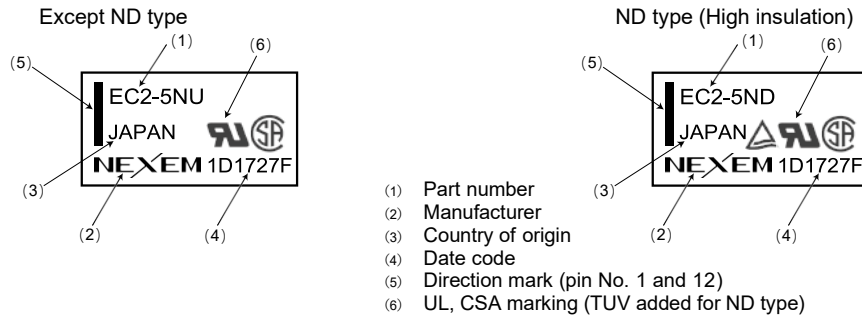

DIMENSIONS

● **EC2 SERIES**

Unit: mm (inch)

DIMENSIONS

STANDARD [TRIMMED LEAD] TYPE
 Non-latch type, Single coil latch type
 HIGH INSULATION [TRIMMED LEAD] TYPE
 Non-latch type

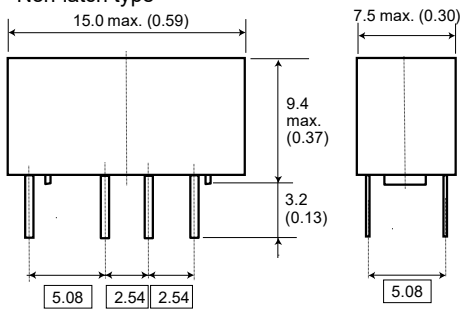

□ is basic size. Other tolerances ± 0.2mm
 Lead size 0.5 x 0.25 ± 0.1
 Trimmed lead type: Lead length 2.8mm

HIGH POWER SWITCHING AND TRIMMED LEAD TYPE
 Non-latch type, Single coil latch type

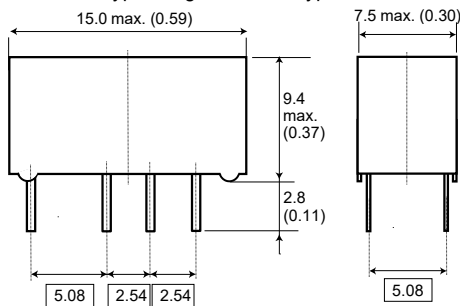

□ is basic size. Other tolerances ± 0.2mm
 Lead size 0.5 x 0.25 ± 0.1

PAD LAYOUTS (Bottom view)

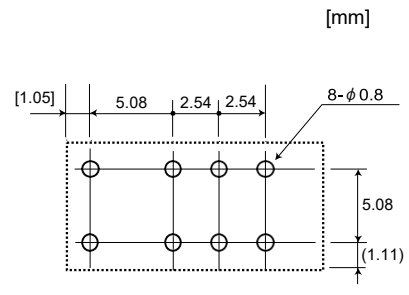

NOTE. General tolerance: ± 0.1

PIN CONFIGURATIONS (Bottom view)

Non-latch type

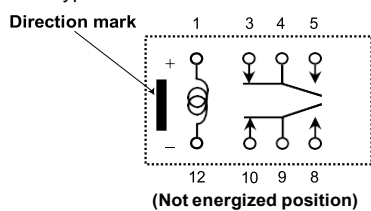

Single coil latch type

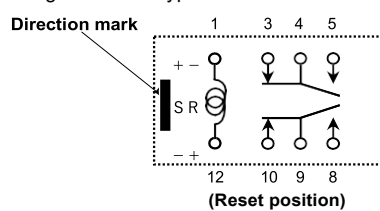

S: Coil polarity for Set
 R: Coil polarity for Reset



● All specifications in this catalog and production status of products are subject to change without notice. Prior to the purchase, please contact EM Devices for updated product data.
 ● Please request for a specification sheet for detailed product data prior to the purchase.
 ● Before using the product in this catalog, please read "NOTES ON CORRECT USE" in the selection guide

Unit: mm (inch)

DIMENSIONS

STANDARD [TRIMMED LEAD] TYPE
Double coil latch type

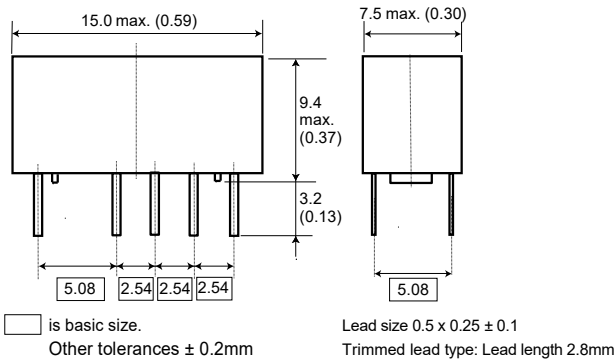

PAD LAYOUTS (Bottom view)

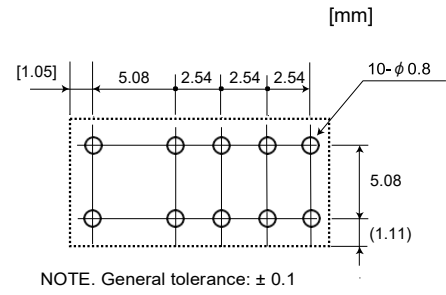

HIGH POWER SWITCHING AND TRIMMED LEAD TYPE
Double coil latch type

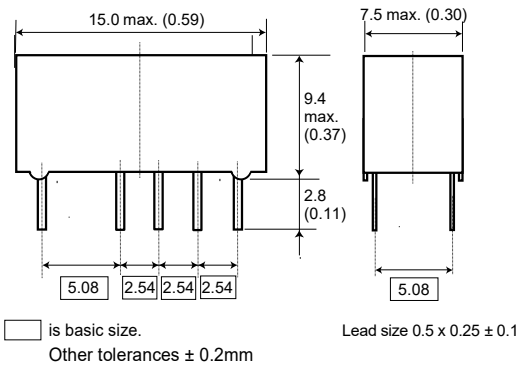

PIN CONFIGURATIONS (Bottom view)

Double coil latch type

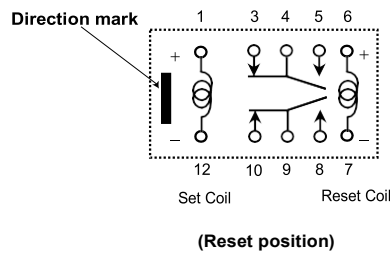

Double coil latch (Special coil winding) type

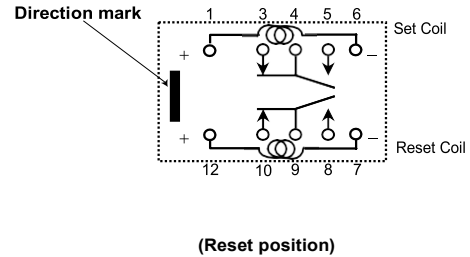

● All specifications in this catalog and production status of products are subject to change without notice. Prior to the purchase, please contact EM Devices for updated product data.
● Please request for a specification sheet for detailed product data prior to the purchase.
● Before using the product in this catalog, please also read "NOTES ON CORRECT USE" in the selection guide

● **EE2 SERIES**

Unit: mm (inch)

DIMENSIONS

STANDARD TYPE

Non-latch type, Single coil latch type

HIGH INSULATION TYPE

Non-latch type

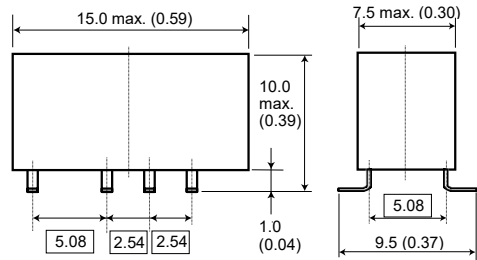

□ is basic size.
Other tolerances ± 0.2mm

Lead size 0.5 x 0.25 ± 0.1

PAD LAYOUTS (Top view)

[mm]

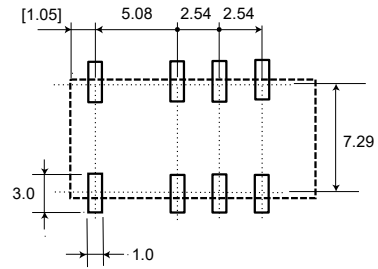

NOTE. General tolerance: ± 0.1

MINIMUM FOOTPRINT TYPE

Non-latch type, Single coil latch type

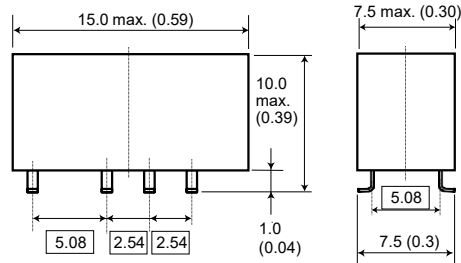

□ is basic size.
Other tolerances ± 0.2mm

Lead size 0.5 x 0.25 ± 0.1

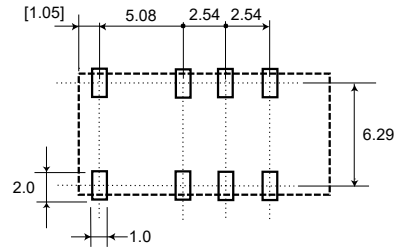

NOTE. General tolerance: ± 0.1

HIGH SOLDER JOINT RELIABILITY TYPE

HIGH POWER SWITCHING AND HIGH SOLDER JOINT RELIABILITY TYPE

Non-latch type, Single coil latch type

HIGH BREAKDOWN VOLTAGE AND HIGH SOLDER JOINT RELIABILITY TYPE

Non-latch type

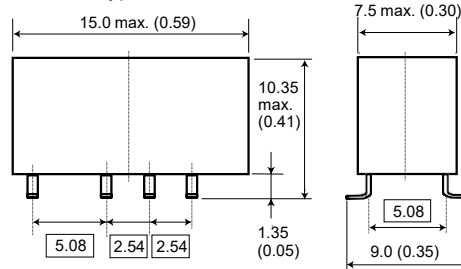

□ is basic size.
Other tolerances ± 0.2mm

Lead size 0.5 x 0.25 ± 0.1

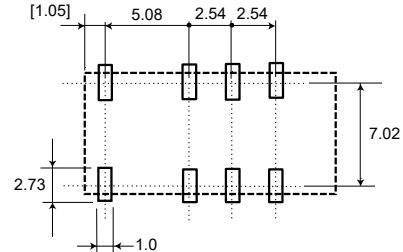

NOTE. General tolerance: ± 0.1

PIN CONFIGURATIONS (Top view)

Non-latch type

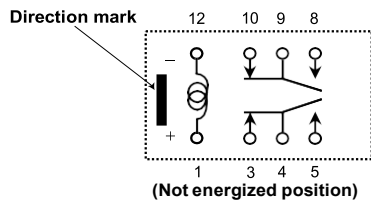

Single coil latch type

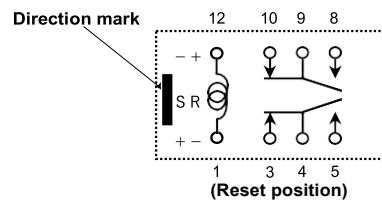

S: Coil polarity for Set
R: Coil polarity for Reset



● All specifications in this catalog and production status of products are subject to change without notice. Prior to the purchase, please contact EM Devices for updated product data.
● Please request for a specification sheet for detailed product data prior to the purchase.
● Before using the product in this catalog, please also read "NOTES ON CORRECT USE" in the selection guide

Unit: mm (inch)

DIMENSIONS
STANDARD TYPE
Double coil latch type

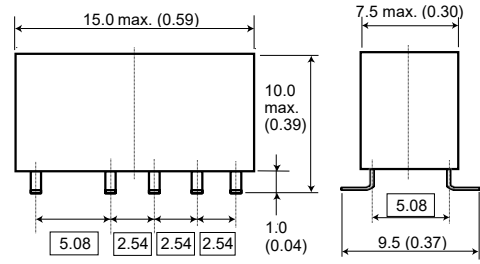

□ is basic size.
Other tolerances ± 0.2mm

Lead size 0.5 x 0.25 ± 0.1

PAD LAYOUTS (Top view)

[mm]

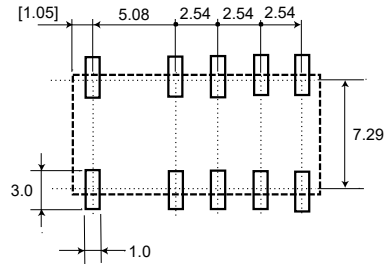

NOTE. General tolerance: ± 0.1

MINIMUM FOOTPRINT TYPE
Double coil latch type

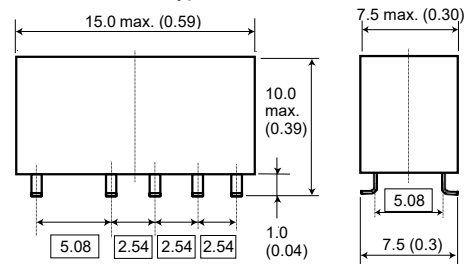

□ is basic size.
Other tolerances ± 0.2mm

Lead size 0.5 x 0.25 ± 0.1

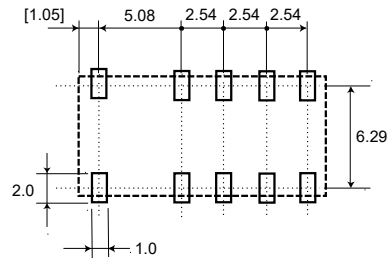

NOTE. General tolerance: ± 0.1

HIGH SOLDER JOINT RELIABILITY TYPE
HIGH POWER SWITCHING AND HIGH SOLDER JOINT RELIABILITY TYPE
Double coil latch type

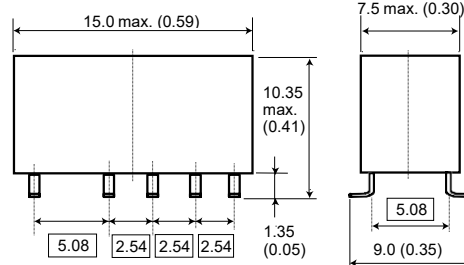

□ is basic size.
Other tolerances ± 0.2mm

Lead size 0.5 x 0.25 ± 0.1

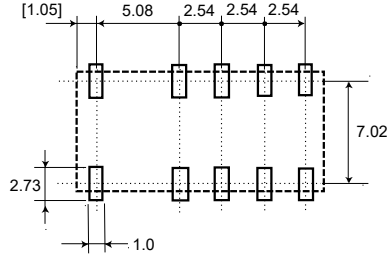

NOTE. General tolerance: ± 0.1

PIN CONFIGURATIONS (Top view)

Double coil latch type

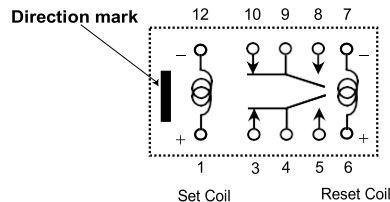

(Reset position)

Double coil latch (Special coil winding) type

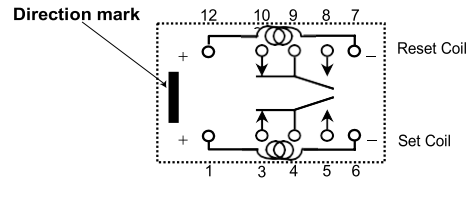

(Reset position)



● All specifications in this catalog and production status of products are subject to change without notice. Prior to the purchase, please contact EM Devices for updated product data.
● Please request for a specification sheet for detailed product data prior to the purchase.
● Before using the product in this catalog, please read "NOTES ON CORRECT USE" in the selection guide

GENERAL SPECIFICATIONS

Contact Form		2 Form C	
Contact Material	Standard	Silver alloy with gold alloy overlay	
	High power switching type	Silver with gold alloy overlay	
Maximum Switching Power	Standard	30 W, 62.5 VA (resistive)	
	High power switching type	60 W, 62.5 VA (resistive)	
Maximum Switching Voltage		220 Vdc, 250 Vac	
Maximum Switching Current		2 A	
Maximum Carrying Current	Standard	2 A	
	High power switching type	3.2 A	
Minimum Contact Ratings		10 mVdc, 10 μA	
Initial Contact Resistance		75 mΩ max.	
Operate Time [Set Time] (Excluding bounce)		Approx. 2 ms [2 ms]	
Release Time [Reset Time] (Excluding bounce)		Approx. 1 ms [2 ms] (Without diode)	
Coil Temperature Rise		13 °C / 100mW, 18 °C / 140mW, 25 °C / 200mW, 28 °C / 230mW	
Insulation Resistance		1000 MΩ at 500 Vdc	
Withstanding Voltage	Between open contacts	Standard	1000 Vac (for one minute), 1500 V surge (10x160 μs *2)
		High Breakdown voltage (NKX) type	Break contact: 1000 Vac (for one minute), 1500 V surge (10x160 μs *2)
			Make contact: 1500 Vac (for one minute), 2500 V surge (2x10 μs *3)
	Between adjacent contacts	Standard	1000 Vac (for one minute), 1500 V surge (10x160 μs *2)
		High Breakdown voltage (NKX) type	1500 Vac (for one minute), 2500 V surge (2x10 μs *3)
	Between coil and contacts	Non-latch type	1500 Vac (for one minute), 2500 V surge (2x10 μs *3)
		Single coil latch type	
	Between set and reset coil	Double coil latch type	1000 Vac (for one minute), 1500 V surge (10x160 μs *2)
		Double coil latch type (Special coil winding type)	250 Vac (for one minute)
	Shock Resistance		735 m/s ² (75 G) (misoperation) 980 m/s ² (100 G) (destructive failure)
Vibration Resistance		10 to 55 Hz, double amplitude 3 mm (196 m/s ²) (misoperation) 10 to 55 Hz, double amplitude 5 mm (294 m/s ²) (destructive failure)	
Ambient Temperature		-40 to +85 °C	
Running Specifications	Non-load	1x10 ⁸ operations (non-latch type) *4 1x10 ⁷ operations (latch type)	
	Load	50 Vdc 0.1 A (resistive), 1x10 ⁶ operations at 85 °C, 5 Hz	
		10 Vdc 10 mA (resistive), 1x10 ⁶ operations at 85 °C, 2 Hz	
		(Only High power switching type) 30 Vdc 2 A (resistive), 1x10 ⁵ operations at 23 °C, 1 Hz	
Weight		Approx. 1.9 g	

* 1 This value is a reference value in the resistive load.

Minimum capacity changes depending on switching frequency and environment temperature and the load.

* 2 rise time: 10 μs, decay time to half crest: 160 μs

* 3 rise time: 2 μs, decay time to half crest: 10 μs

* 4 This shows the number of operations without fatal defects. Stable characteristics are maintained for 1 × 10⁷ operations.



● All specifications in this catalog and production status of products are subject to change without notice. Prior to the purchase, please contact EM Devices for updated product data.

● Please request for a specification sheet for detailed product data prior to the purchase.

● Before using the product in this catalog, please also read "NOTES ON CORRECT USE" in the selection guide

COIL SPECIFICATIONS

Non-latch Type

at 20 °C

Nominal Coil Voltage (Vdc)	Coil Resistance (Ω)±10%	Must Operate Voltage* (Vdc)	Must Release Voltage* (Vdc)	Nominal Operating Power (mW)
3	64.3	2.25	0.3	140
4.5	145	3.38	0.45	140
5	178	3.75	0.5	140
9	579	6.75	0.9	140
12	1028	9.0	1.2	140
24	2880	18.0	2.4	200

Single Coil Latch Type

at 20 °C

Nominal Coil Voltage (Vdc)	Coil Resistance (Ω)±10%	Must Set Voltage* (Vdc)	Must Reset Voltage* (Vdc)	Nominal Operating Power (mW)
3	90	2.25	2.25	100
4.5	202.5	3.38	3.38	100
5	250	3.75	3.75	100
9	810	6.75	6.75	100
12	1440	9.0	9.0	100
24	5760	18.0	18.0	100

Note: Apply the coil voltage so that the No.1 pin is on the + side when set and the No.12 pin is on the + side when reset.

Double Coil Latch Type (Can not be driven by reverse polarity for reverse operation)

at 20 °C

Nominal Coil Voltage (Vdc)		Coil Resistance (Ω)±10%	Must Set Voltage* (Vdc)	Must Reset Voltage* (Vdc)	Nominal Operating Power (mW)
3	S	64.3	2.25	-	140
	R	64.3	-	2.25	
4.5	S	145	3.38	-	140
	R	145	-	3.38	
5	S	178	3.75	-	140
	R	178	-	3.75	
9	S	579	6.75	-	140
	R	579	-	6.75	
12	S	1028	9.0	-	140
	R	1028	-	9.0	
24	S	4114	18.0	-	140
	R	4114	-	18.0	

Note: S: Set coil (pin No.1 ... (+), pin No.12 ... (-)) R: Reset coil (pin No.6... (+), pin No.7... (-))

Non-latch High Insulation (ND) Type

at 20 °C

Nominal Coil Voltage (Vdc)	Coil Resistance (Ω)±10%	Must Operate Voltage* (Vdc)	Must Release Voltage* (Vdc)	Nominal Operating Power (mW)
3	45	2.25	0.3	200
4.5	101	3.38	0.45	200
5	125	3.75	0.5	200
9	405	6.75	0.9	200
12	720	9.0	1.2	200
24	2504	18.0	2.4	230



●All specifications in this catalog and production status of products are subject to change without notice. Prior to the purchase, please contact EM Devices for updated product data.
 ●Please request for a specification sheet for detailed product data prior to the purchase.
 ●Before using the product in this catalog, please also read "NOTES ON CORRECT USE" in the selection guide

Non-latch High Breakdown Voltage (NKX) Type

at 20 °C

Nominal Coil Voltage (Vdc)	Coil Resistance (Ω)±10%	Must Operate Voltage* (Vdc)	Must Release Voltage* (Vdc)	Nominal Operating Power (mW)
3	39.1	2.25	0.3	230
4.5	88.0	3.38	0.45	230
12	626	9.0	1.2	230

Note: * Test by pulse voltage

** The latch type relays should be initialized at appointed position before using by avoid wrong operation.

SAFETY STANDARD AND RATING

UL Recognized (UL508) File No E73266	
Standard	High power switching type
30 Vdc, 2 A (Resistive)	30 Vdc, 3 A (Resistive)
110 Vdc, 0.3 A (Resistive)	110 Vdc, 0.3 A (Resistive)
125 Vac, 0.5 A (Resistive)	125 Vac, 0.5 A (Resistive)

CSA Certificated (CSA C22.2 No14) File No LR46266
30 Vdc, 2 A (Resistive)
110 Vdc, 0.3 A (Resistive)
125 Vac, 0.5 A (Resistive)

TUV Certificate (IEC61810-1/EN61810-1)	
File No. R9751153**	File No. R9750561
NU, NJ, NUH, NUX Type (Non-latch and Single coil latch)	ND Type (Non-latch)
Creepage and clearance of coil to contact is more than 2 mm. (According to EN62368-1)	
Basic insulation class	Supplementary insulation class

*High power switching type, etc., are not supported TUV certified.

RECOMMENDED RELAY DRIVE CONDITIONS

Drive under conditions.

Non-latch type	Voltage: within ±5% of nominal voltage	Ambient temperature - 40 to +85 °C
Single coil latch type Double coil latch type	Square pulse (rise and fall time is rapid) pulse height: within ±5% of nominal voltage pulse width: more than 10 ms	



- All specifications in this catalog and production status of products are subject to change without notice. Prior to the purchase, please contact EM Devices for updated product data.
- Please request for a specification sheet for detailed product data prior to the purchase.
- Before using the product in this catalog, please also read "NOTES ON CORRECT USE" in the selection guide

PART NUMBER SYSTEM

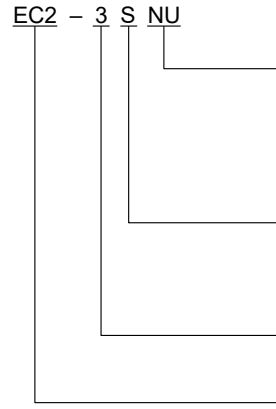

Option
 NU: Standard
 NJ: Trimmed lead type
 ND: High insulation type
 NQJ: High power switching and trimmed lead type
 NY: Special coil winding type (Double coil latch type only)

Latch type
 Nil: Non-latch type
 S: Single coil latch type
 T: Double coil latch type

Nominal coil voltage
 (A numerical value of coil voltage)

EC2 series

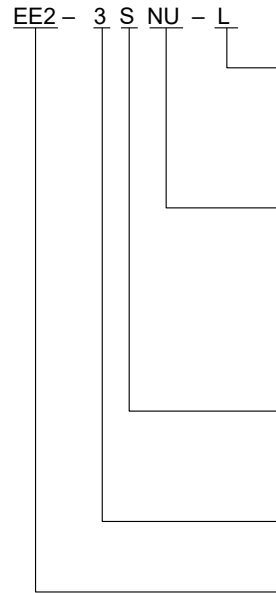

Packing
 Nil: Tube
 L: Embossed carrying tape
 L9: Embossed carrying tape with Moisture Barrier Bag (MBB) (MSL 2a)

Option
 NU: Standard
 NUH: Minimum footprint type
 NUX: High solder joint reliability type
 ND: High insulation type
 NKX: High breakdown voltage and high solder joint reliability type
 NQX: High power switching and solder joint reliability type
 NY: Special coil winding type (Double coil latch type only)

Latch type
 Nil: Non-latch type
 S: Single coil latch type
 T: Double coil latch type

Nominal coil voltage
 (A numerical value of coil voltage)

EE2 series



●All specifications in this catalog and production status of products are subject to change without notice. Prior to the purchase, please contact EM Devices for updated product data.
 ●Please request for a specification sheet for detailed product data prior to the purchase.
 ●Before using the product in this catalog, please also read "NOTES ON CORRECT USE" in the selection guide

ORDERING PART NUMBERS

□ EC2 series

Option		Nominal Coil Voltage (Vdc)	Coil Type		
Terminal	Packing		Non-latch	Single Coil Latch	Double Coil Latch
Standard	Tube	3	EC2-3NU	EC2-3SNU	EC2-3TNU
		4.5	EC2-4.5NU	EC2-4.5SNU	EC2-4.5TNU
		5	EC2-5NU	EC2-5SNU	EC2-5TNU
		9	EC2-9NU	EC2-9SNU	EC2-9TNU
		12	EC2-12NU	EC2-12SNU	EC2-12TNU
		24	EC2-24NU	EC2-24SNU	EC2-24TNU
Trimmed lead	Tube	3	EC2-3NJ	EC2-3SNJ	EC2-3TNJ
		4.5	EC2-4.5NJ	EC2-4.5SNJ	EC2-4.5TNJ
		5	EC2-5NJ	EC2-5SNJ	EC2-5TNJ
		9	EC2-9NJ	EC2-9SNJ	EC2-9TNJ
		12	EC2-12NJ	EC2-12SNJ	EC2-12TNJ
		24	EC2-24NJ	EC2-24SNJ	EC2-24TNJ

□ EC2 series High Insulation Type (ND Type)

Option		Nominal Coil Voltage (Vdc)	Coil Type
Terminal	Packing		Non-latch
Standard	Tube	3	EC2-3ND
		4.5	EC2-4.5ND
		5	EC2-5ND
		9	EC2-9ND
		12	EC2-12ND
		24	EC2-24ND

□ EC2 series High Power Switching Type (NQJ Type)

Option		Nominal Coil Voltage (Vdc)	Coil Type		
Terminal	Packing		Non-latch	Single Coil Latch	Double Coil Latch
Trimmed lead	Tube	3	EC2-3NQJ	EC2-3SNQJ	EC2-3TNQJ
		4.5	EC2-4.5NQJ	EC2-4.5SNQJ	EC2-4.5TNQJ
		5	EC2-5NQJ	EC2-5SNQJ	EC2-5TNQJ
		9	EC2-9NQJ	EC2-9SNQJ	EC2-9TNQJ
		12	EC2-12NQJ	EC2-12SNQJ	EC2-12TNQJ
		24	EC2-24NQJ	EC2-24SNQJ	EC2-24TNQJ



● All specifications in this catalog and production status of products are subject to change without notice. Prior to the purchase, please contact EM Devices for updated product data.
 ● Please request for a specification sheet for detailed product data prior to the purchase.
 ● Before using the product in this catalog, please also read "NOTES ON CORRECT USE" in the selection guide

□ EE2 series

Option		Nominal Coil Voltage (Vdc)	Coil Type		
Terminal	Packing		Non-latch	Single Coil Latch	Double Coil Latch
Standard	Tube	3	EE2-3NU	EE2-3SNU	EE2-3TNU
		4.5	EE2-4.5NU	EE2-4.5SNU	EE2-4.5TNU
		5	EE2-5NU	EE2-5SNU	EE2-5TNU
		9	EE2-9NU	EE2-9SNU	EE2-9TNU
		12	EE2-12NU	EE2-12SNU	EE2-12TNU
		24	EE2-24NU	EE2-24SNU	EE2-24TNU
	Taping	3	EE2-3NU-L	EE2-3SNU-L	EE2-3TNU-L
		4.5	EE2-4.5NU-L	EE2-4.5SNU-L	EE2-4.5TNU-L
		5	EE2-5NU-L	EE2-5SNU-L	EE2-5TNU-L
		9	EE2-9NU-L	EE2-9SNU-L	EE2-9TNU-L
		12	EE2-12NU-L	EE2-12SNU-L	EE2-12TNU-L
		24	EE2-24NU-L	EE2-24SNU-L	EE2-24TNU-L
	Taping (MBB)	3	EE2-3NU-L9	EE2-3SNU-L9	EE2-3TNU-L9
		4.5	EE2-4.5NU-L9	EE2-4.5SNU-L9	EE2-4.5TNU-L9
		5	EE2-5NU-L9	EE2-5SNU-L9	EE2-5TNU-L9
		9	EE2-9NU-L9	EE2-9SNU-L9	EE2-9TNU-L9
		12	EE2-12NU-L9	EE2-12SNU-L9	EE2-12TNU-L9
		24	EE2-24NU-L9	EE2-24SNU-L9	EE2-24TNU-L9
Minimum footprint	Tube	3	EE2-3NUH	EE2-3SNUH	EE2-3TNUH
		4.5	EE2-4.5NUH	EE2-4.5SNUH	EE2-4.5TNUH
		5	EE2-5NUH	EE2-5SNUH	EE2-5TNUH
		9	EE2-9NUH	EE2-9SNUH	EE2-9TNUH
		12	EE2-12NUH	EE2-12SNUH	EE2-12TNUH
		24	EE2-24NUH	EE2-24SNUH	EE2-24TNUH
	Taping	3	EE2-3NUH-L	EE2-3SNUH-L	EE2-3TNUH-L
		4.5	EE2-4.5NUH-L	EE2-4.5SNUH-L	EE2-4.5TNUH-L
		5	EE2-5NUH-L	EE2-5SNUH-L	EE2-5TNUH-L
		9	EE2-9NUH-L	EE2-9SNUH-L	EE2-9TNUH-L
		12	EE2-12NUH-L	EE2-12SNUH-L	EE2-12TNUH-L
		24	EE2-24NUH-L	EE2-24SNUH-L	EE2-24TNUH-L
	Taping (MBB)	3	EE2-3NUH-L9	EE2-3SNUH-L9	EE2-3TNUH-L9
		4.5	EE2-4.5NUH-L9	EE2-4.5SNUH-L9	EE2-4.5TNUH-L9
		5	EE2-5NUH-L9	EE2-5SNUH-L9	EE2-5TNUH-L9
		9	EE2-9NUH-L9	EE2-9SNUH-L9	EE2-9TNUH-L9
		12	EE2-12NUH-L9	EE2-12SNUH-L9	EE2-12TNUH-L9
		24	EE2-24NUH-L9	EE2-24SNUH-L9	EE2-24TNUH-L9
High Solder joint reliability	Tube	3	EE2-3NUX	EE2-3SNUX	EE2-3TNUX
		4.5	EE2-4.5NUX	EE2-4.5SNUX	EE2-4.5TNUX
		5	EE2-5NUX	EE2-5SNUX	EE2-5TNUX
		9	EE2-9NUX	EE2-9SNUX	EE2-9TNUX
		12	EE2-12NUX	EE2-12SNUX	EE2-12TNUX
		24	EE2-24NUX	EE2-24SNUX	EE2-24TNUX
	Taping	3	EE2-3NUX-L	EE2-3SNUX-L	EE2-3TNUX-L
		4.5	EE2-4.5NUX-L	EE2-4.5SNUX-L	EE2-4.5TNUX-L
		5	EE2-5NUX-L	EE2-5SNUX-L	EE2-5TNUX-L
		9	EE2-9NUX-L	EE2-9SNUX-L	EE2-9TNUX-L
		12	EE2-12NUX-L	EE2-12SNUX-L	EE2-12TNUX-L
		24	EE2-24NUX-L	EE2-24SNUX-L	EE2-24TNUX-L
	Taping (MBB)	3	EE2-3NUX-L9	EE2-3SNUX-L9	EE2-3TNUX-L9
		4.5	EE2-4.5NUX-L9	EE2-4.5SNUX-L9	EE2-4.5TNUX-L9
		5	EE2-5NUX-L9	EE2-5SNUX-L9	EE2-5TNUX-L9
		9	EE2-9NUX-L9	EE2-9SNUX-L9	EE2-9TNUX-L9
		12	EE2-12NUX-L9	EE2-12SNUX-L9	EE2-12TNUX-L9
		24	EE2-24NUX-L9	EE2-24SNUX-L9	EE2-24TNUX-L9



● All specifications in this catalog and production status of products are subject to change without notice. Prior to the purchase, please contact EM Devices for updated product data.
 ● Please request for a specification sheet for detailed product data prior to the purchase.
 ● Before using the product in this catalog, please also read "NOTES ON CORRECT USE" in the selection guide

□ EE2 series High Insulation Type (ND Type)

Option		Nominal Coil Voltage (Vdc)	Coil Type
Terminal	Packing		Non-latch
Standard	Tube	3	EE2-3ND
		4.5	EE2-4.5ND
		5	EE2-5ND
		9	EE2-9ND
		12	EE2-12ND
		24	EE2-24ND
	Taping	3	EE2-3ND-L
		4.5	EE2-4.5ND-L
		5	EE2-5ND-L
		9	EE2-9ND-L
		12	EE2-12ND-L
		24	EE2-24ND-L
	Taping (MBB)	3	EE2-3ND-L9
		4.5	EE2-4.5ND-L9
		5	EE2-5ND-L9
		9	EE2-9ND-L9
		12	EE2-12ND-L9
		24	EE2-24ND-L9

□ EE2 series High Breakdown Voltage Type (NKX Type)

Option		Nominal Coil Voltage (Vdc)	Coil Type
Terminal	Packing		Non-latch
High Solder joint reliability	Tube	3	EE2-3NKX
		4.5	EE2-4.5NKX
		12	EE2-12NKX
	Taping	3	EE2-3NKX-L
		4.5	EE2-4.5NKX-L
		12	EE2-12NKX-L
	Taping (MBB)	3	EE2-3NKX-L9
		4.5	EE2-4.5NKX-L9
		12	EE2-12NKX-L9

□ EE2 series High Power Switching Type (NQX Type)

Option		Nominal Coil Voltage (Vdc)	Coil Type		
Terminal	Packing		Non-latch	Single Coil Latch	Double Coil Latch
High Solder joint reliability	Taping (MBB)	3	EE2-3NQX-L9	EE2-3SNQX-L9	EE2-3TNQX-L9
		4.5	EE2-4.5NQX-L9	EE2-4.5SNQX-L9	EE2-4.5TNQX-L9
		5	EE2-5NQX-L9	EE2-5SNQX-L9	EE2-5TNQX-L9
		9	EE2-9NQX-L9	EE2-9SNQX-L9	EE2-9TNQX-L9
		12	EE2-12NQX-L9	EE2-12SNQX-L9	EE2-12TNQX-L9
		24	EE2-24NQX-L9	EE2-24SNQX-L9	EE2-24TNQX-L9

Note:

1. Only MBB packaging part numbers meet MSL (L9: MSL 2a). However, it does not fully conform to JEDEC standards such as classification temperature. Please note that part numbers other than MBB packaging do not meet MSL.
2. The packaging specification for EE2 relay high power switching type is only Taping with MBB (MSL 2a). Please note that other packaging specifications are not supported.



●All specifications in this catalog and production status of products are subject to change without notice. Prior to the purchase, please contact EM Devices for updated product data.
 ●Please request for a specification sheet for detailed product data prior to the purchase.
 ●Before using the product in this catalog, please also read "NOTES ON CORRECT USE" in the selection guide

PERFORMANCE DATA

☐ COIL TEMPERATURE RISE

Temperature is measured by coil resistance.

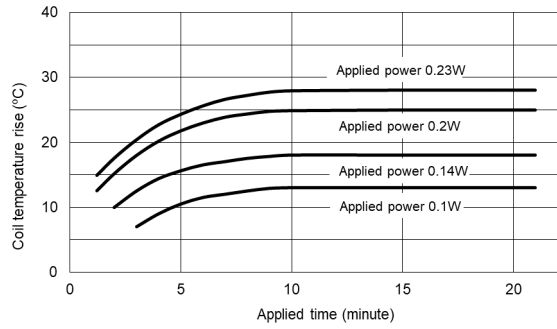
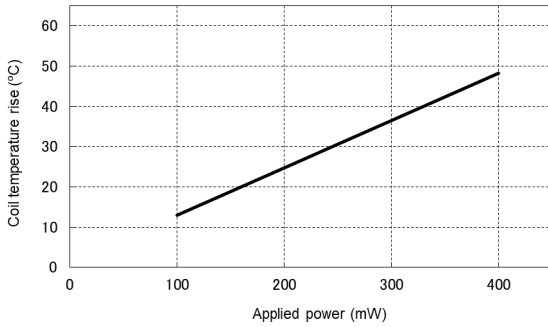

☐ SWITCHING CAPACITY

This is allowed maximum value.

Inquire with EM Devices for maximum value under continuous

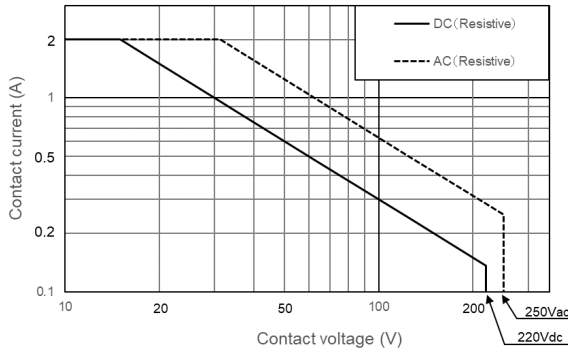

(Standard)

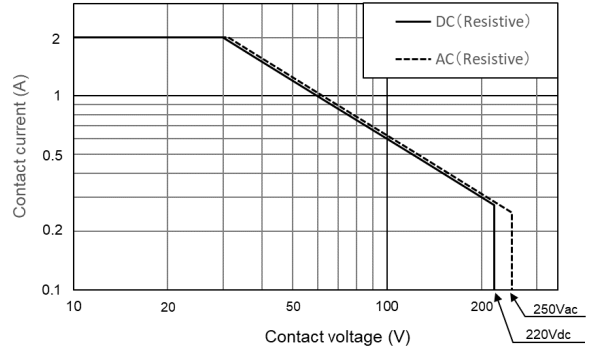

(High power switching type)



● All specifications in this catalog and production status of products are subject to change without notice. Prior to the purchase, please contact EM Devices for updated product data.
 ● Please request for a specification sheet for detailed product data prior to the purchase.
 ● Before using the product in this catalog, please also read "NOTES ON CORRECT USE" in the selection guide

□ MAXIMUM COIL VOLTAGE

This is a maximum value of permissible alteration.

Inquire with EM Devices under continuous use.

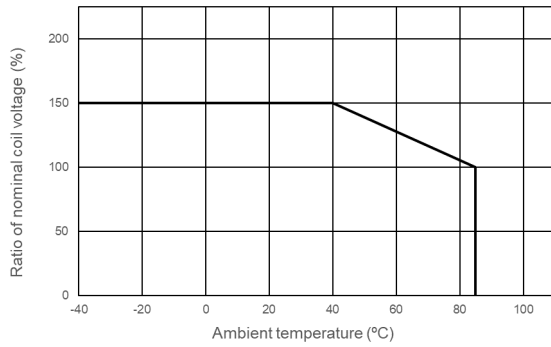

□ APPLIED POWER VS. TIMING (Sample: EC2-5NU)

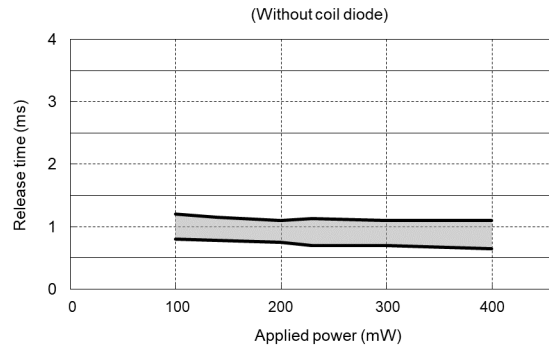
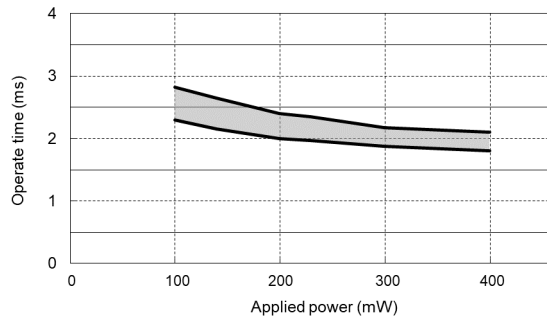

● All specifications in this catalog and production status of products are subject to change without notice. Prior to the purchase, please contact EM Devices for updated product data.
 ● Please request for a specification sheet for detailed product data prior to the purchase.
 ● Before using the product in this catalog, please also read "NOTES ON CORRECT USE" in the selection guide

□ OPERATE AND RELEASE VOLTAGE VS. AMBIENT TEMPERATURE

This shows a typical change of operate (release) voltage. The value of must operate is estimated, so coil voltage must be applied more than this value for safety operation. For hot start operation, please inquire with EM Devices.

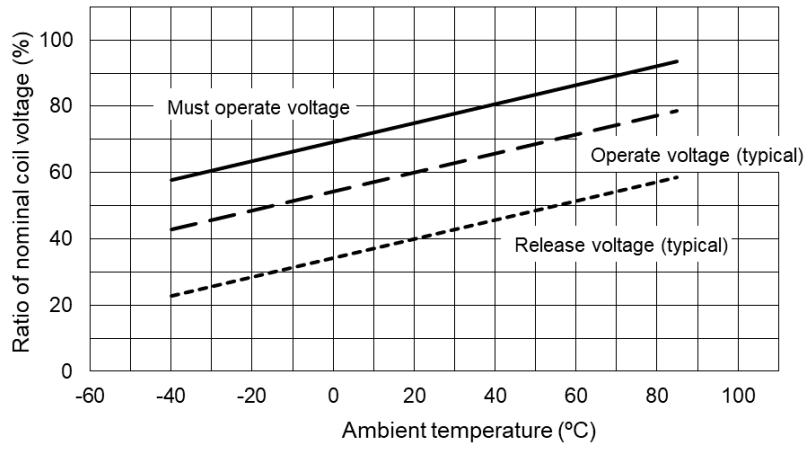

□ RUNNING TEST (Non-load)

(Load: none, Drive: 5Vdc, 50Hz, 50%duty, Ambient temperature: room temperature, Sample: EC2-5NU, 20pieces)

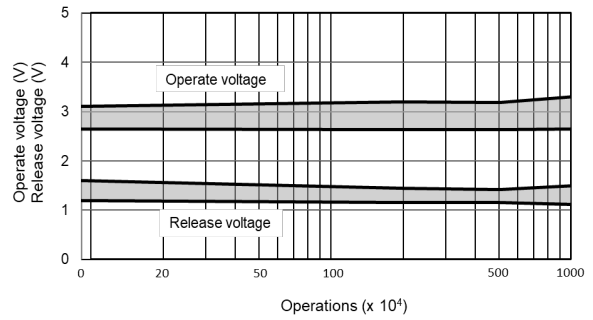
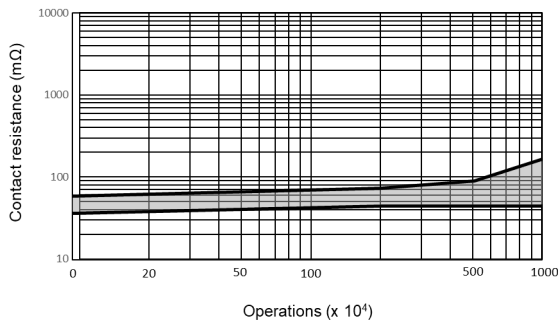

□ RUNNING TEST (Load)

(Load: 50Vdc 0.1A resistive, Drive: 5Vdc, 5Hz, 50%duty, Ambient temperature: 85°C, Sample: EC2-5NU, 10pieces)

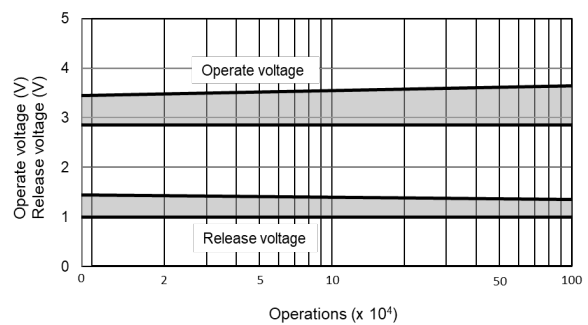
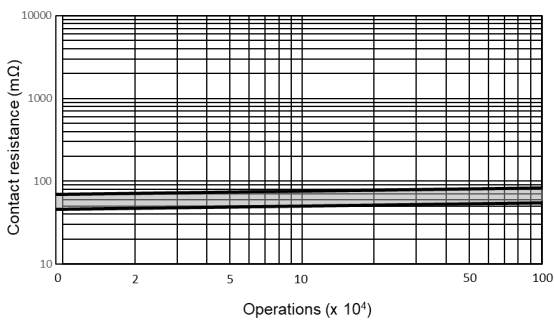

● All specifications in this catalog and production status of products are subject to change without notice. Prior to the purchase, please contact EM Devices for updated product data.
 ● Please request for a specification sheet for detailed product data prior to the purchase.
 ● Before using the product in this catalog, please also read "NOTES ON CORRECT USE" in the selection guide

□ BREAKDOWN VOLTAGE

Sample: EC2-5NU 10pieces

(a) Between open contacts

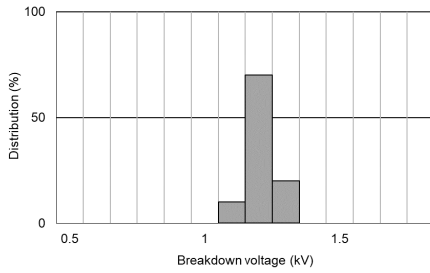

(b) Between adjacent contacts

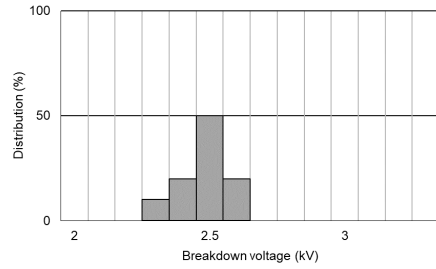

(c) Between coil and contacts

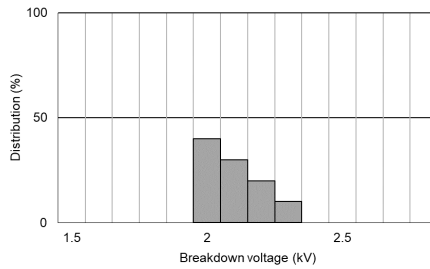

□ ALTERNATION OF VOLTAGE AT DENSELY MOUNTING (Magnet interference)

Alternation of operate voltage

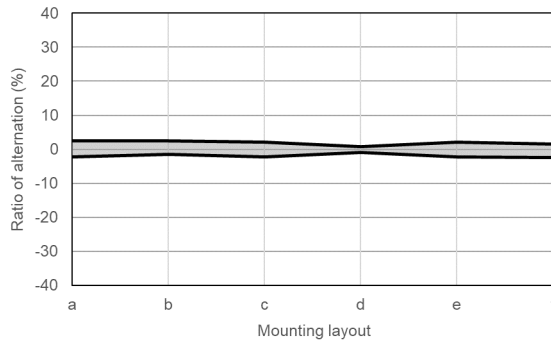

Alternation of release voltage

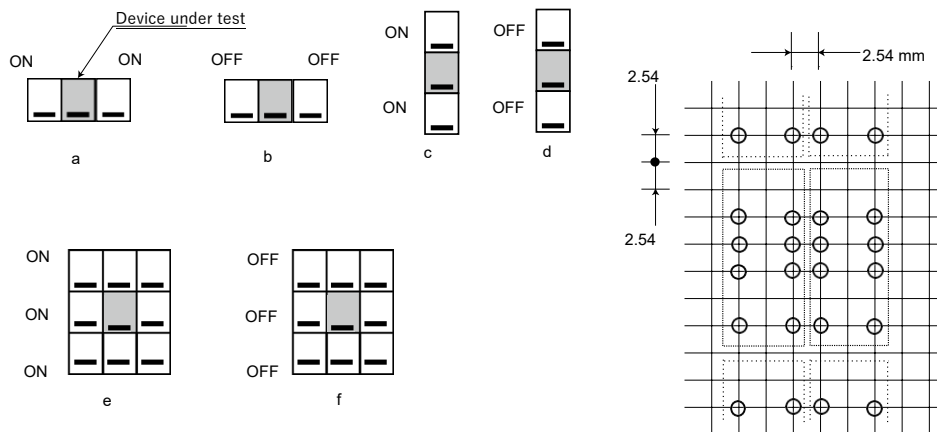
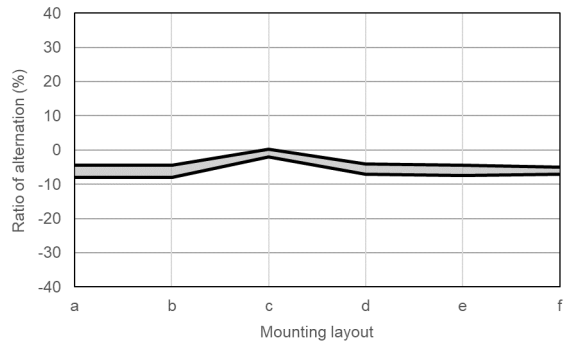

● All specifications in this catalog and production status of products are subject to change without notice. Prior to the purchase, please contact EM Devices for updated product data.
 ● Please request for a specification sheet for detailed product data prior to the purchase.
 ● Before using the product in this catalog, please also read "NOTES ON CORRECT USE" in the selection guide

PACKING DIMENSIONS

(Unit: mm)

TUBE PACKING (EC2/EE2)

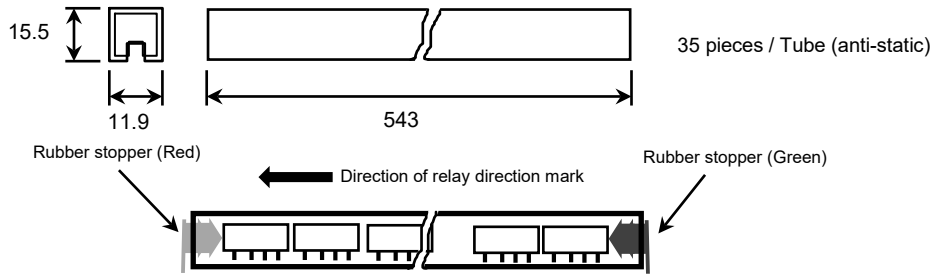

TAPE PACKING (EE2)

APPEARANCE

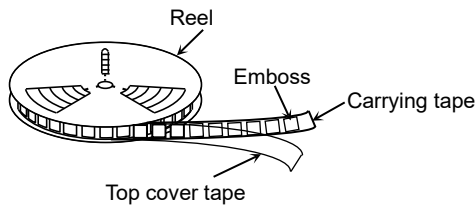

Reel material: Corrugated Cardboard (L)
PS (L9: MBB)
Relay quantity: 500 pieces / Reel
L9 has two reels are sealed in one MBB.
Reel diameter: 380 mm

TAPE DIMENSIONS

For EE2-xxxx-L

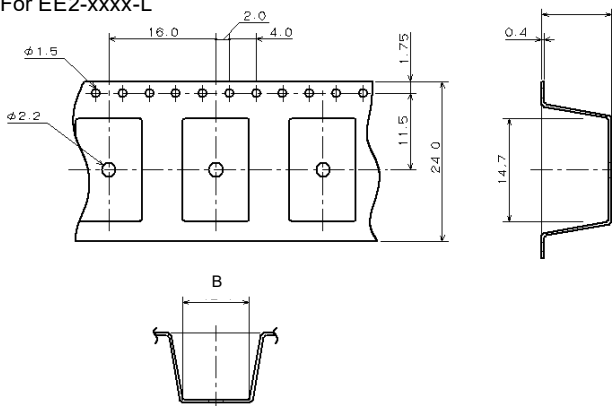

	A	B
EE2-xxNU-L	Max.10.9	10.0
EE2-xxND-L		
EE2-xxNUX-L		
EE2-xxNKX-L		
EE2-xxNUH-L	Max.11.1	8.0

For EE2-xxxx-L9

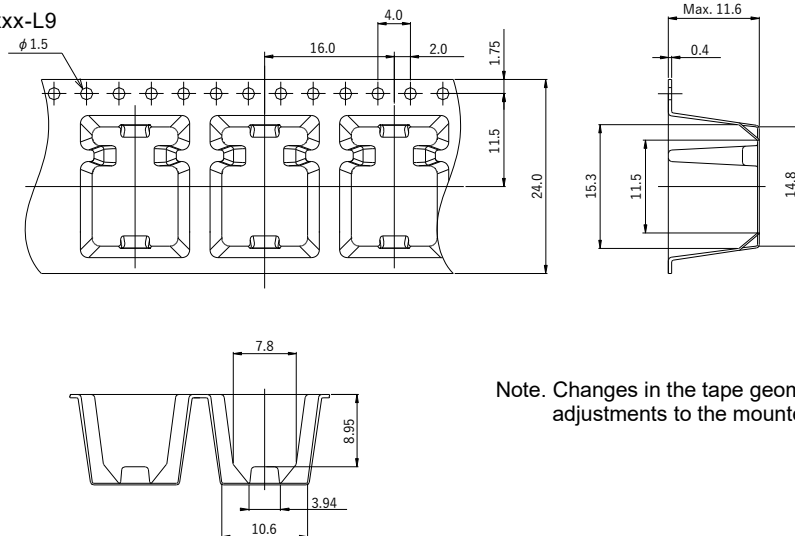

Note. Changes in the tape geometry may require adjustments to the mounted machine.



- All specifications in this catalog and production status of products are subject to change without notice. Prior to the purchase, please contact EM Devices for updated product data.
- Please request for a specification sheet for detailed product data prior to the purchase.
- Before using the product in this catalog, please also read "NOTES ON CORRECT USE" in the selection guide

RELAY DIRECTION AND TAPE CARRYING DIRECTION

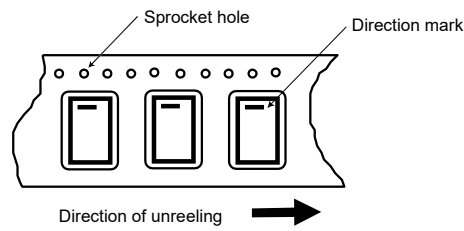

SOLDERING TEMPERATURE CONDITION

THROUGH-HOLE MOUNTING (EC2)

1. Automatic soldering

Preheating (Terminal): 110~ 120°C / 110s. max.
 Solder temperature: 260°C max.
 Soldering time: 5s max.

Note: EM Devices recommends cooling down a printed circuit board less than 110°C within 40s after soldering. The above are flow soldering conditions. Check the actual soldering condition to use other automatic soldering methods.

2. Manual soldering (by soldering iron)

Soldering temperature (Tip): 350°C max.
 Soldering time: 3 s max.

Note: Heating of this product by automatic soldering and manual soldering is limited to a total of three times.

SURFACE-MOUNTING TYPE (EE2)

1. Reflow Method (NEXEM recommend profile)

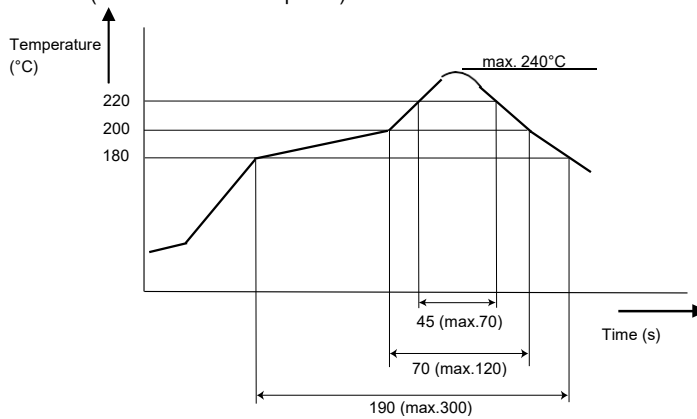

Note:

1. Temperature profile shows printed circuit board surface temperature on the relay terminal portion.
2. Heating by reflow should be limited to two times. However, allow sufficient time for cooling of the product between the first and second reflow.
3. Check the actual soldering condition to use other method except above mentioned temperature profiles.



●All specifications in this catalog and production status of products are subject to change without notice. Prior to the purchase, please contact EM Devices for updated product data.
 ●Please request for a specification sheet for detailed product data prior to the purchase.
 ●Before using the product in this catalog, please also read "NOTES ON CORRECT USE" in the selection guide

NOTE ON CORRECT USE

1. Notes on contact load

Make sure that the contact load is within the specified range; otherwise, the lifetime of the contacts will be shortened considerably.

Note that the running performance shown is an example, and that it varies depending on parameters such as the type of load, switching frequency, driver circuit, and ambient temperature under the actual operating conditions. Evaluate the performance by using the actual circuit before using the relay.

2. Driving relays

- If the internal connection diagram of a relay shows + and - symbols on the coil, apply the rated voltage to the relay in the specified direction. If a rippled DC current source is used, abnormalities such as beat at the coil may occur.
- The maximum voltage that can be applied to the coil of the relay varies depending on the ambient temperature. Generally, the higher the voltage applied to the coil, the shorter the operating time. Note, however, that a high voltage also increases the bounce of the contacts and the contact opening and closing frequency, which may shorten the lifetime of the contacts.
- If the driving voltage waveform of the relay coil rises and falls gradually, the inherent performance of the relay may not be fully realized. Make sure that the voltage waveform instantaneously rises and falls as a pulse.

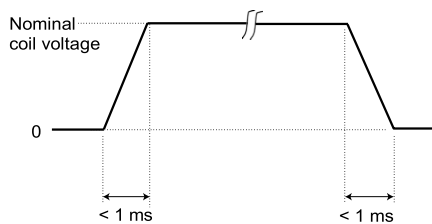

- For a latching relay, apply a voltage to the coil according to the polarity specified in the internal connection diagram of the relay.
- If a current is applied to the coil over a long period of time, the coil temperature rises, promoting generation of organic gas inside the relay, which may result in faulty contacts. In this case, use of a latching relay is recommended.
- The operating time and release time indicate the time required for each contact to close after the voltage has been applied to or removed from the coil. However, because the relay has a mechanical structure, a bounce state exists at the end of the operating and release times. Furthermore, because additional time is required until the contact stabilizes after being in a high-resistance state, care must be taken when using the relay at high speeds.

3. Operating environment

- Make sure that the relay mounted in the application set is used within the specified temperature range. Use of a relay at a temperature outside this range may adversely affect insulation or contact performance.

- If the relay is used for a long period of time in highly humid (RH 85% or higher) environment, moisture may be absorbed into the relay. This moisture may react with the NOx and SOx generated by glow discharges that occur when the contacts are opened or closed, producing nitric or sulfuric acid. If this happens, the acid produced may corrode the metallic parts of the relay, causing operational malfunction.
- If any material containing silicone (silicone rubber, silicone oil, and silicone-based coating material) is used in the neighborhood of relay, there is some possibility that these materials will emit silicone gas that will penetrate the relay. In this case, the switching contact may generate silicone on the surface of contacts. This silicone may result in contact failure. Avoid use of relay in such an environment.
- Because the operating temperature range varies depending on the humidity, use the relay in the temperature range illustrated in the figure below. Prevent the relay from being frozen and avoid the generation of condensation.

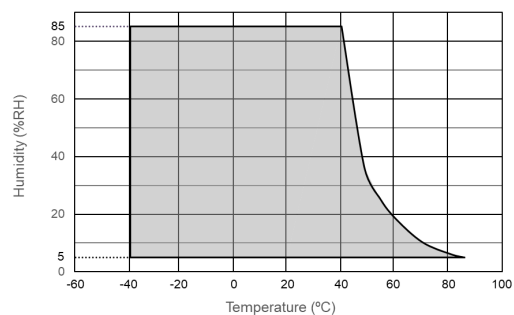

- The same applies when the relay is stored or transported. Keep the upper-limit value of the temperature to which the relay is exposed after it is removed from the carton box to within 50°C. Please also refer to "5. Handling" for SMT relays.
- Permanent magnets are used in polarized relays. For this reason, when magnets, transformers, or speakers are located nearby the relay characteristics may change and faulty operations may result.
- The relay maintains constant sealability under normal atmospheric pressure (810 to 1,200 hPa). Its sealability may be degraded or the relay may be deformed and malfunction if it is used under barometric conditions exceeding the specified range. Avoid using vacuum oven during baking or drying cleaning solutions.
- If excessive vibration or shock is applied to the relay, it may malfunction, and the contacts remain closed. Vibration or shock applied to the relay during operation may cause considerable damage to or wearing of the contacts. Note that operation of a snap switch mounted close to the relay or shock due to the operation of magnetic solenoid may also cause malfunctioning.



●All specifications in this catalog and production status of products are subject to change without notice. Prior to the purchase, please contact EM Devices for updated product data.
 ●Please request for a specification sheet for detailed product data prior to the purchase.
 ●Before using the product in this catalog, please also read "NOTES ON CORRECT USE" in the selection guide

4. Notes on mounting relays

- When mounting a relay onto a PC board using an automatic chip mounter, if excessive force is applied to the cover of the relay when the relay is chucked or inserted, the cover may be damaged, or the characteristics of the relay degraded. Keep the force applied to the relay to within 1 kg.
- Avoid bending the pins to temporarily secure the relay to the PC board. Bending the pins may degrade sealability or adversely affect the internal mechanism.
- It is recommended to solder the relay onto a PC board under the following conditions:

<1> Reflow soldering

Refer to the recommended soldering temperature profile. Please note that excessive heating beyond the specified peak temperature or heating time will damage the airtightness.

<2> Flow soldering

Solder temperature: 260°C max., Time: 5s max.

Preheating (Terminals): 110~120°C / 110s. (max.)

EM Devices recommends cooling down a printed circuit board less than 110°C within 40 seconds after soldering.

<3> Manual soldering

Soldering temperature (Tip): 350°C, Time: 3s max.

Avoid immersing the relay in cleaning solvent immediately after soldering due to the danger of thermal shock being applied to the relay.

- Use an alcohol-based or water-based cleaning solvent. Never use thinner and benzene because they may damage the relay housing.
- Do not use ultrasonic cleaning because the vibration energy generated by the ultrasonic waves may cause the contacts to remain closed.
- When using a vacuum oven to dry the cleaning solution, the relay's seal-ability may be compromised. Avoid drying conditions lower than normal atmospheric pressure.

5. Handling

- Relays are packaged in magazine cases for shipment. If a space is created in the case after some relays have been removed, be sure to insert a stopper to secure the remaining relays in the case. If relays are not well secured, vibration during transportation may cause malfunctioning of the contacts.
- Exercise care in handling the relay so as to avoid dropping it or allowing it to fall. Do not use a relay that has been dropped. If a relay drops from a workbench to the floor, a shock of 9,800 m/s² (1,000 G) or more is applied to the relay, possibly damaging its functions. Even if a light shock has been applied to the relay, thoroughly evaluate its operation before using it.
- Latching relays are factory-set to the reset state for shipment. A latching relay may be set, however, by vibration or shock applied while being transported. Be sure to forcibly reset the relay before using it in the application set. Also note that the relay may be set by unexpected vibration or shock when it is used in a portable set.

- The sealability of a surface mount type (SMT) relay may be lost if the relay absorbs moisture and is then heated during soldering. When storing relays, therefore, observe the following points:

<1> For standard packing

(a). Pack state

Term: Less than 12 months after our shipment. (Recommend using the product within 3 months if possible.)

Conditions: <30 °C, <60% RH

(b). Require bake before mounting, when relays not used within the above (a) period or was stored outside above (a) conditions.

Simple relay: Please dehumidify 85 ± 5 °C, 48 hours or more after transferring to a heat-resistant container.

Tape packing: Please dehumidify 50 ± 5 °C, 300 hours or more in reel condition.

Tube packaging should be baking on simple relays, removed from tube.

Relays after baking should be mounted within 3 months under the conditions in (a).

Standard packaging specification products do not meet with the JEDEC standard's Moisture Sensitivity Level (MSL) because they are not MBB packaged. If MSL compliance is required, use MBB packaging specification products.

<2> For MBB packing

(a). MBB state

Term: Less than 12 months after our shipment

Conditions: <30 °C, <60% RH

(b). After opening of MBB

Term: Within the time limit indicated on the caution label attached to MBB.

Conditions: <30 °C, <60% RH

(c). Require bake before mounting, when relays not used within the above (a) or (b) period or was stored outside above conditions.

Simple relay: Please dehumidify 85 ± 5 °C, 48 hours or more after transferring to a heat-resistant container.

Tape packing: Please dehumidify 50 ± 5 °C, 300 hours or more in reel condition. Please keep in mind that barrier pack needs to remove in that case.

Relays after baking should be mounted within the time limits according to MSL on the caution label under the conditions in (b).

The humidity indicator card included in MBB package immediately after opening should also be used as a basis for judging baking procedures.



●All specifications in this catalog and production status of products are subject to change without notice. Prior to the purchase, please contact EM Devices for updated product data.
 ●Please request for a specification sheet for detailed product data prior to the purchase.
 ●Before using the product in this catalog, please also read "NOTES ON CORRECT USE" in the selection guide

No part of this document may be copied or reproduced in any form or by any means without the prior written consent of EM Devices Corporation. EM Devices Corporation assumes no responsibility for any errors which may appear in this document.

EM Devices Corporation does not assume any liability for infringement of patents, copyrights or other intellectual property rights of third parties by or arising from use of a device described herein or any other liability arising from use of such device. No license, either express, implied or otherwise, is granted under any patents, copyrights or other intellectual property rights of EM Devices Corporation or others.

While EM Devices Corporation has been making continuous effort to enhance the reliability of its electronic components, the possibility of defects cannot be eliminated entirely. To minimize risks of damage or injury to persons or property arising from a defect in an EM Devices electronic component, customers must incorporate sufficient safety measures in its design, such as redundancy, fire-containment, and anti-failure features.

EM Devices' products are classified into the following three quality grades: "Standard", "Special", and "Specific". The Specific quality grade applies only to devices developed based on a customer designated "quality assurance program" for a specific application. The recommended applications of a device depend on its quality grade, as indicated below. Customers must check the quality grade of each device before using it in a particular application. If customers intend to use EM Devices' products for applications other than those specified for Standard quality grade, they should contact an EM Devices sales representative in advance, as specifications must be exchanged with EM Devices.

Standard: Computers, office equipment, communications equipment, test and measurement equipment, audio and visual equipment, home electronic appliances, machine tools, personal electronic equipment and industrial robots

Special: Transportation equipment (automobiles, trains, ships, etc.), traffic control systems, anti-disaster systems, anti-crime systems, safety equipment and medical equipment (not specifically designed for life support)

Specific: Aircrafts, aerospace equipment, submersible repeaters, nuclear reactor control systems, life support systems or medical equipment for life support, etc.

The quality grade of EM Devices' products is "Standard" unless otherwise specified in EM Devices' Data Sheets or Data Books. EM Devices cannot guarantee the quality of our products if the product is used for applications other than "Standard" applications without exchanging specifications with EM Devices, or if the product is used for "Standard" applications under conditions or in environments not described in this document.

(Note)

The information in this document is subject to change without notice. Please refer to the latest data sheet when designing for mass production.



- All specifications in this catalog and production status of products are subject to change without notice. Prior to the purchase, please contact EM Devices for updated product data.
- Please request for a specification sheet for detailed product data prior to the purchase.
- Before using the product in this catalog, please also read "NOTES ON CORRECT USE" in the selection guide